

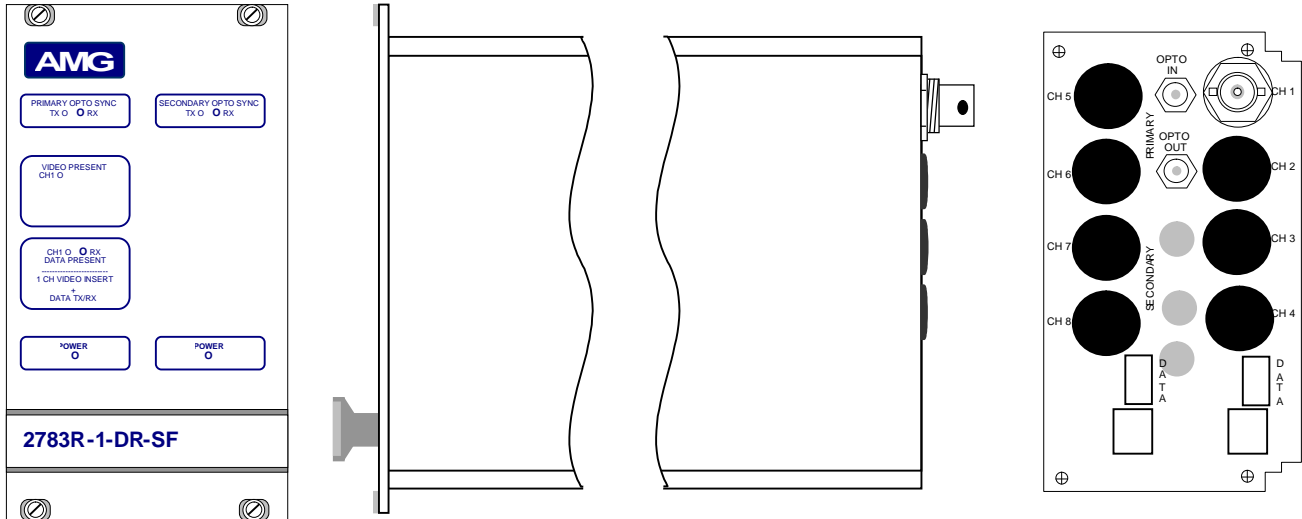

# AMG2783R-1-DR-SF Instruction Manual

## Single Channel Video Insert Unit with Bi-directional Data Dual Redundant on a single fibre ring



The **AMG2783R-1-DR-SF** is a single channel video insert unit designed to transmit a video signal on to a single dual redundant optical fibre ring. It also provides a RS485/RS422 bi-directional data channel. It is designed to be mounted in an **AMG2005** 19" rackmount subrack.

The **AMG2783R-1-DR-SF** is designed to operate with the **AMG2784RN-DR-SF** eight channel video and data receiver. Each receiver will 'drop off' up to eight video channels that are being transmitted around the single fibre ring.

<b>Index</b>	<b>Page No.</b>
<b>Introduction</b> .....	<b>2</b>
Unit Functional Schematic.....	2
Optical System Connection .....	2
Dual Redundant Operation.....	3
<b>Connections</b> .....	<b>4</b>
Video Input connection.....	4
Optical Connections .....	4
Power Connections .....	4
Data Connections.....	5
<b>Indicators</b> .....	<b>6</b>
<b>Physical Information</b> .....	<b>6</b>
Dimensions.....	6
Mounting Details.....	6
<b>Configuration of the RS422/RS485 Data Channel</b> .....	<b>7</b>
<b>Video Input Channel Configuration</b> .....	<b>7</b>
<b>SW1 Switch Settings</b> .....	<b>8</b>
<b>Removal from the Case</b> .....	<b>9</b>
<b>Safety</b> .....	<b>9</b>

## Introduction

### Unit Functional Schematic

The **AMG2783R-1 DR-SF** transmits and receives optical signals from both a primary and a secondary optical channel. These optical channels are transmitted on the same optical fibre in different directions, operating on different wavelengths. The primary channel operates on 1550nm and the secondary channel on 1310nm.

The **AMG2783R-1-DR-SF** receives and drops off a data signal transmitted from an **AMG2784R-DR-SF** receiver. It then inserts a video and data signal onto the outgoing optical signal. The video signal is inserted on 1 of 8 channels available on the optical signal. The insert channel number is set by SW1 inside the unit (see below). If the video channel is set to a channel that already has a video signal on it, this unit will overwrite this in-coming video signal.

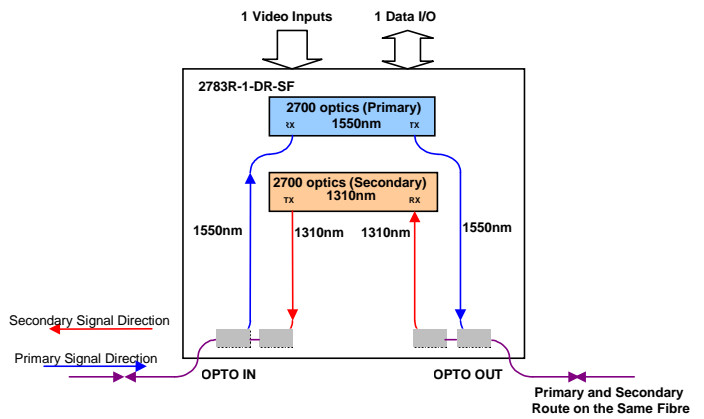

In normal operation where connection of both the previous unit and the subsequent unit are OK, the video and data signals are transmitted on the primary optical output and the data received from the primary optical input. The secondary optical input is independent and is regenerated on the secondary output.

If the primary optical input signal is not present, the unit will shut down the secondary optical output to inform the previous unit that the optical signal route is not OK. The previous unit will then send out the video and data signals on its secondary optical output in the opposite direction. This signal will be repeated around the ring to get back to this **AMG2783R-1-DR-SF** on the secondary optical route. As the primary optical input is not present on this unit, the data signal will now be taken from the secondary optical input. Thus maintaining integrity of the data transmission.

If the secondary optical input signal is not present, the unit will assume that the route to the next unit is not OK and send out the video and data signal on the secondary optical output. This video and data will be transmitted to the next unit around the ring in the opposite direction on the secondary optical route.

### Optical System Connection

The **AMG2783R-1-DR-SF** units are designed to be connected in a ring system.

In a ring system **AMG2783R-1-DR-SF**, **AMG2783R-2-DR-SF** and **AMG2783R-4-DR-SF**, single, dual and four channel insert units respectively can be combined to make up an 8 channel video transmission system as illustrated below, dropping off the video signals at a **AMG2784R-DR-SF**. As each unit regenerates the optical signal, the optical dynamic range between each optically connected node is 15dB.

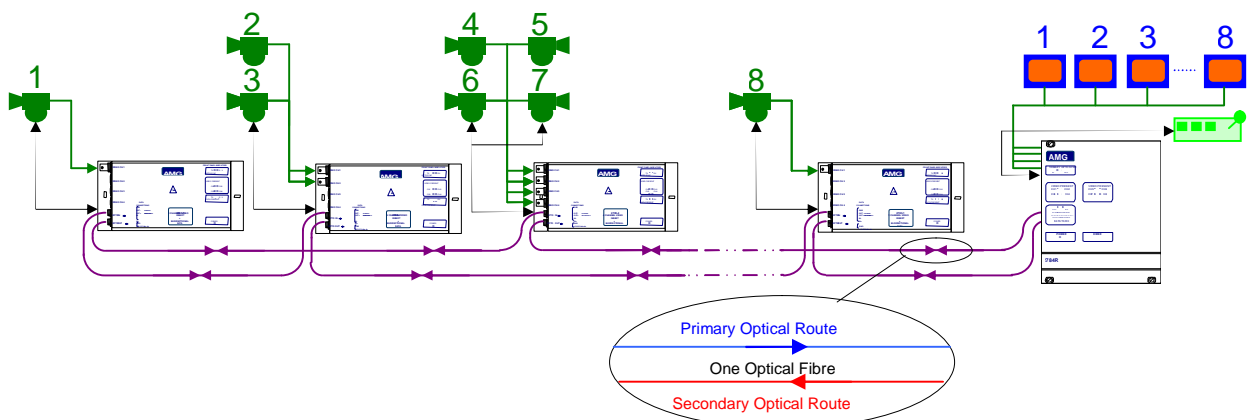

## Dual Redundant Operation

If a fibre link is broken, operation of the ring continues by making use of the secondary optical fibre route as below:

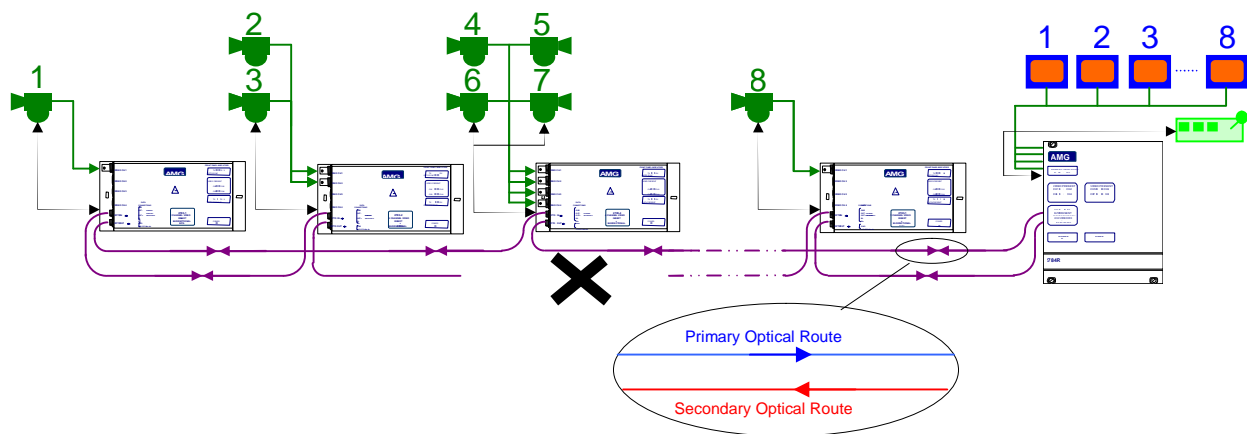

If multiple breaks occur, operation is maintained will all the units still physically connected to the receiver. For the scenario shown below camera signals and control would now be lost from cameras 1, 2 and 3 as there is now no physical connection between the transceivers and the receiver. However operation of cameras 4,5,6,7 and 8 remains fully functional.

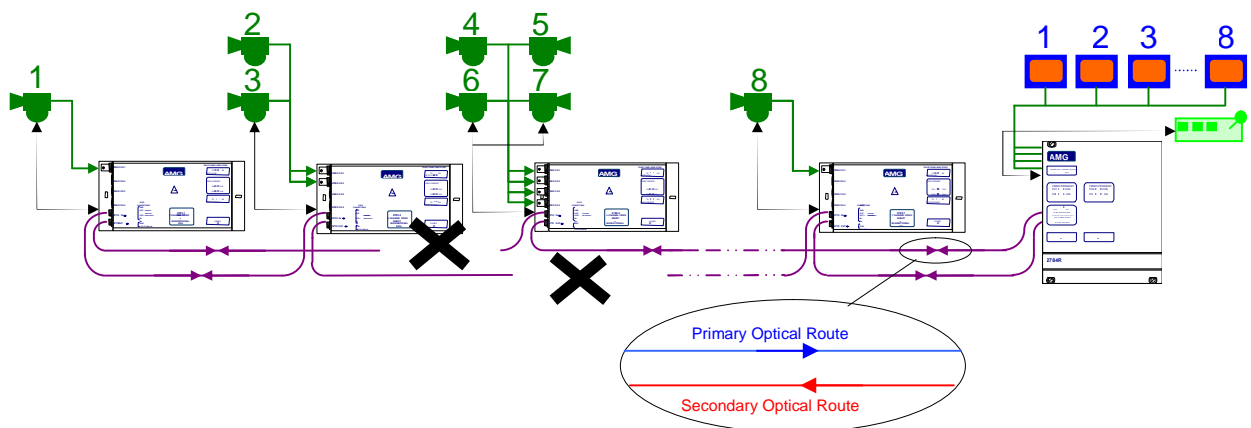

Note that where necessary repeaters can be added at nodes to increase the average distance between nodes.

# Connections

## Video Input Connection

Connector ..... 75 ohm BNC Socket.  
 Input Impedance ..... 75 ohm terminated.  
 Input Level ..... 1 volt p-p nominal  
 Frequency Response ..... 10Hz to 5.75MHz min.  
 See below for **video input channel configuration**

## Optical Connections

### PRIMARY OPTO OUT

Connector ..... FC/PC  
 Primary Optical Launch Power ..... -6dBm  
 Wavelength ..... 1550nm

Secondary Optical Sensitivity ..... -21dBm  
 Wavelength ..... 1310nm

### PRIMARY OPTO IN

Connector ..... FC/PC  
 Primary Optical Sensitivity ..... -21dBm  
 Wavelength ..... 1550nm

Secondary Optical Launch Power ..... -6dBm  
 Wavelength ..... 1310nm

## Power Connection

Power supply ..... from plug in connection on the 2000 or 2005 subrack  
 Power consumption ..... 15 Watts max.

## Data Connections

Data Connector ..... 5 way removable spring terminal connector (2.5mm spacing)  
 Manufacturers Part No. Phoenix/Combicom FK-MC-0.5/5-ST-2.5  
 AMG Part No G15098-00

Data Channels ..... 1

Connections RS422 4 wire ..... See schematic

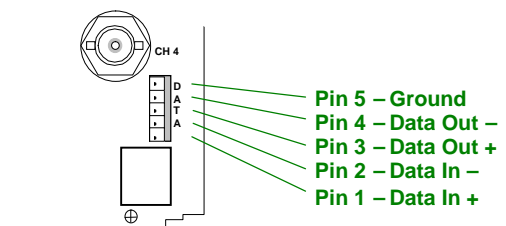

Connections RS485 4 wire ..... See schematic

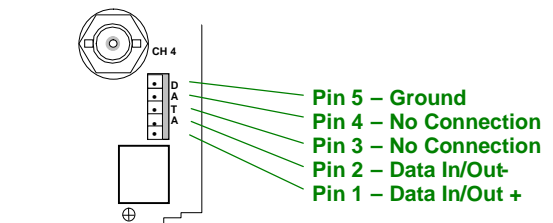

Connections RS232 ..... See schematic

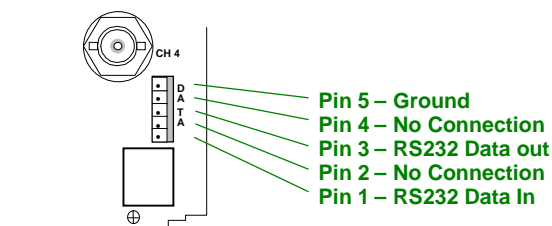

Protocol..... RS232  
 SW1 switch position 9 on, switch position 10 on  
 SW2 all off

RS485 2wire  
 SW1 switch position 9 off, switch position 10 off  
 SW2 see below

RS422 4 wire Bus'ed or point to point  
 SW1 switch position 9 off, switch position 10 off  
 SW2 see below

See below for **Configuration of the RS485 / RS422 data channel** and description of tristate operation

**Indicators**

Power .....	Green	- unit powered
	Off	- no power applied to unit
Primary Opto Sync TX .....	Green	- Primary optical channel transmitting
	Off	- Primary optical channel not transmitting
Primary Opto Sync RX .....	Green	- Primary optical channel receiving
	Off	- Primary optical channel not receiving
Secondary Opto Sync TX .....	Green	- Secondary optical channel transmitting
	Off	- Secondary optical channel not transmitting
Secondary Opto Sync RX .....	Green	- Secondary optical channel receiving
	Off	- Secondary optical channel not receiving
Video Present CH1 .....	Green	- video signal present on video CH1 input BNC
	Off	- no video present on video CH1 input BNC
Data Present TX .....	Green input	- logic one present on the corresponding data
	Red input	- logic zero present on the corresponding data
	Off input	- tri-state present on the corresponding data
This represents the data signals being transmitted on the optical fibre		
Data Present RX .....	Green output	- logic one present on the corresponding data
	Red output	- logic zero present on the corresponding data
	Off output	- tri-state present on the corresponding data

This represents the data signals being received on the optical fibre

## Physical Information

### Dimensions

Height ..... 3U Plug-in  
Width..... 14HP  
Depth ..... 170mm excluding connectors  
Weight..... 800grams

### Mounting Details

The unit is designed to be mounted within a 2005 Subrack on standard card guides. Note the AMG standard racks are supplied with guide rails every 14HP. In order to fit this unit in the Subrack with 21 HP plug-ins, some sets of card guides may have to be moved by pulling gently on the card guides.

The 2005 series subrack is fitted with a 100 watt power supply.

### Configuration of the Data Channel

SW1 and SW2 determine the protocol of the data channel. This can be RS232, RS485 or RS422. (See below for **removal from the case** and access to SW1 and SW2)

**Mode 1 – RS485 two wire half duplex transmission.**

**Mode 2 – RS422 four wire full duplex transmission.**

In this mode the RS422 output will transmit a tristate condition as well as logic high and logic low for systems which require bus-ing of the RS422 four-wire connection.

MODE	Configuration Details	SW2 position 1	SW2 position 2	SW2 position 3	SW2 position 4	SW1 position 9	SW1 position 10
1	RS-422 4 wire Point-to-Point - and RS-422 BUS system	OFF	OFF	OFF	OFF	OFF	OFF
2	RS-485 2 wire BUS systems	OFF	ON	ON	ON	OFF	OFF

**Note: - when used with a 2788 with the individual channel A data channels routed to a separate data card (not on-board data at the RX), RS485 operation and the tri-state RS422 output is not available. RS485 operation can only be selected if on-board data is selected at the RX.**

The data input for both the RS485 and the RS422 modes detects a tri-state input condition by monitoring the differential voltage level across the input. A differential level below 500mV positive or negative will be detected as a tristate condition. A level above 500mV positive or negative will be detected as a logic 1 or logic zero respectively. **It is important therefore to terminate the RS485 bus or the RS422 input bus using 120ohms if a pre-bias is present on the RS485 or RS422 bus.** A large number of third party equipment manufacturers apply a pre-bias on their RS485 bus. This pre-bias is applied by pulling one arm of the RS485 bus high (+5 volts) and the other arm low (0 volts) using high value resistors within the third party equipment. In order to ensure that the AMG2700 equipment detects a tri-state condition, then these resistors should have a value above 1kohm.

**Mode 3 – RS232 full duplex transmission.**

MODE	Configuration Details	SW2 position 1	SW2 position 2	SW2 position 3	SW2 position 4	SW1 position 9	SW1 position 10
3	RS-232 Point to Point	OFF	OFF	OFF	OFF	ON	ON

**Note: - the data channel is set at Mode 1 – RS485 operation at the factory unless otherwise requested.**

## Video input channel configuration

The video present on the video input can be inserted on one of eight video channels transmitted on the optical fibre. The input channel number is set by SW1 on the primary channel TX board. (See below for **removal of the PCB** and access to SW1)

The channel number is set by the SW1 switch positions 1 to 3 – see below.

Video Input Channel Number	SW1 position 1	SW1 position 2	SW1 position 3
1	OFF	OFF	OFF
2	ON	OFF	OFF
3	OFF	ON	OFF
4	ON	ON	OFF
5	OFF	OFF	ON
6	ON	OFF	ON
7	OFF	ON	ON
8	ON	ON	ON

It is normal to set each AMG2700 insert unit to a different channel number. If a number is used twice the second unit connected 'down stream' on the primary optical route will 'over-write' the first unit and the video signal will be lost.

The channel number is only required to be set on SW1 on the primary channel TX card. Positions 1 to 3 on SW1 on the secondary channel TX card do not effect the operation of the equipment.

## SW1 Switch Settings

Only switch positions 1 to 3 should be set by the user, all other switch settings are set at the factory as follows:

Primary Channel TX Card (Single Channel Video TX Card)

Switch Position	Description	Setting
1	Video channel configuration	See above
2	Video channel configuration	See above
3	Video channel configuration	See above
4	Primary / Secondary Board Setting	ON
5	Dual Redundant / Not dual redundant	ON
6	Not Used	OFF
7	Not Used	OFF
8	On board data / Separate data card	ON
9	RS232 Select	OFF
10	RS232 Select	OFF

## Secondary Channel TX Card (Zero Channel Video TX Card)

Switch Position	Description	Setting
1	Not Used	OFF
2	Not Used	OFF
3	Not Used	OFF
4	Primary / Secondary Board Setting	OFF
5	Dual Redundant / Not dual redundant	ON
6	Not Used	OFF
7	Not Used	OFF
8	Not Used	OFF
9	Not Used	OFF
10	Not Used	OFF

### **Removal from the Case**

**Note:** - The 2700 PCB's are static sensitive. Handle with proper care and use normal electrostatic discharge (ESD) procedures. Use properly grounded protection (for example, wrist straps) when handling the PCB. The switch positions can be accessed without pulling out the boards from the case fully. It is recommended that the boards are slid out just sufficient to access the switches (~40mm) in order to reduce the possibility of damage to the optical fibres and electronic circuits.

In order to remove the case (to access SW1 and SW2)

- 1.1. Loosen and remove the four screws on the top and bottom of the unit's rear panel.
- 1.2. Slide the PCB assembly connected to the rear panel back from the case by about 40mm.
- 1.3. Ensure that the optical fibre is not trapped.
- 1.4. The Primary Channel TX card is the PCB which has the video input BNC attached through the rear panel labelled CH1.

SW1 and SW2 can be found on the bottom right hand corner of each board and are labelled, close to the rear panel. The switch position are labelled on the switch, switch position 1 is always the furthest from the edge of the PCB.

When re-inserting the main PCB into the housing take care not to trap the optical fibre or the board interconnection cables.

Fasten the rear panel with the screws.

### **Safety**

The 2700 series of products uses a Class 1 laser system in accordance with EN 60825-2:2000 and as such the optical power emitted from the optical connector is regarded as eye safe under all operating conditions.

However it is always advisable to follow good practice when working with optical fibre systems. This includes:

- Do not stare with unprotected eyes or with any unapproved collimating device at fibre ends or connector faces, or point them at other people.
- Use only approved filtered or attenuating viewing aids

For other safety issues and advice on good practice associated with the optical fibres systems see EN 60825-2:2000 or your local safety officer.

There are no user serviceable parts within the AMG2700 products.

In case of problem or failure contact your local support centre or AMG Systems Ltd, Technical Support Department on tel. +44 (0) 1767 600777.

See unit data sheet for full specification.